

LOC		DIST		REVISIONS			
GP	00	REV	DATE	BY	CHK	APPV	
G1	REVISED PER ECR-15-007038		01OCT2015	NK		PQ	

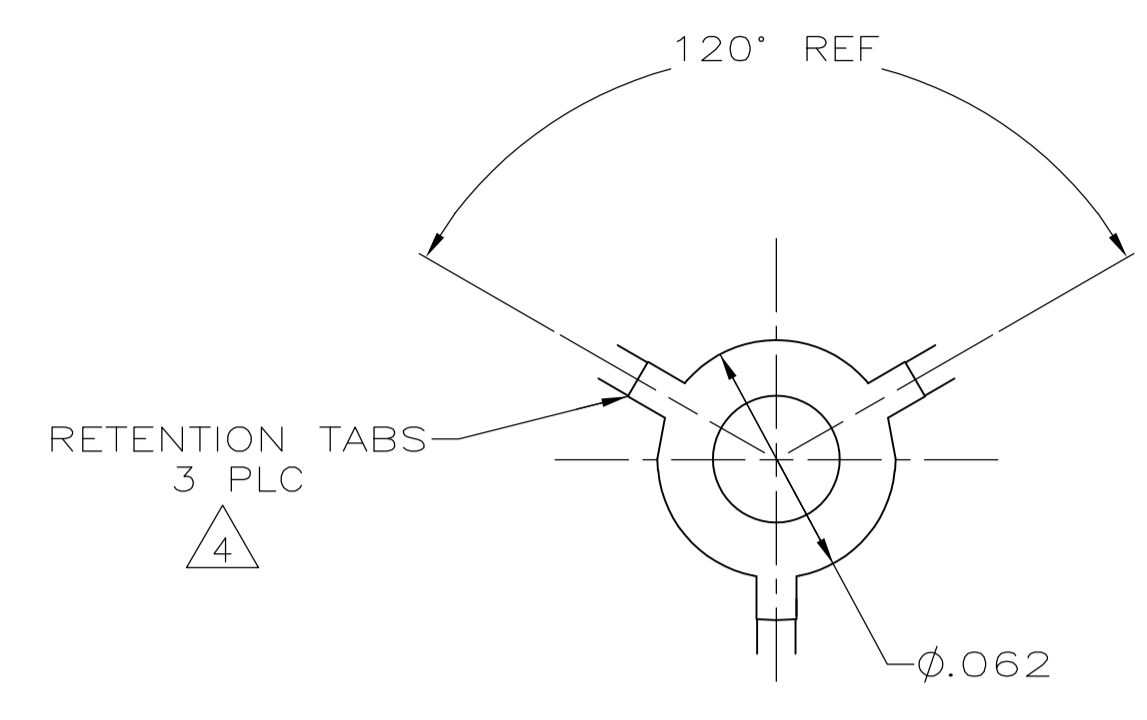

VIEW A-A
SCALE 20:1

- 1 MATERIAL: HEADER - POLYESTER UL94V-0 (BLACK)
POST - COPPER ALLOY.
- 2 SOLDER SIDE OF P.C. BOARD SHOWN.
- 3 PARTS COMPLY WITH AMP SOLDERABILITY SPEC 109-11-2.
- 4 THE RETENTION TABS PROVIDE A ONE-TIME INTERFERENCE FIT IN THE .078 DIAMETER BOARD HOLE FOR HEADER ASSEMBLY RETENTION DURING SOLDERING.
- 5 LATCH DETENT FEATURE OCCURS 2 PLACES ON EACH END (MAXIMUM OF FOUR PER PART). FOR 2 THRU 5 CIRCUIT HEADERS, LATCH FEATURE OCCURS BETWEEN EACH CIRCUIT.
- 6 COORDINATE DIMENSION APPLIES FROM CENTER OF ACTUAL FEATURE.
- 7 POST: 93/7 BRIGHT TIN-LEAD PLATING (-2 THRU -14) OR 100% MATTE TIN PLATING (-32 THRU -44).
- 8 POST MUST WITHSTAND 3.0 LBS (13.34 NEWTONS) MIN FORCE WITHOUT DISLODGING, EITHER DIRECTION.
- 9 TWO SIDES OF TAPER, AS SHOWN, MUST BE PLATED. TYPICAL, BOTH ENDS.
- 10 TWO SIDES OF TAPER, AS SHOWN, AND TIP MAY BE UNPLATED. TYPICAL, BOTH ENDS.
- 11 SLOTS MAY OR MAY NOT APPEAR ON THESE PARTS.
- 12 UL RECOGNIZED (UR) LOGO AND CSA LOGO WILL APPEAR ON THE SIDE OF THE PART. THE AMP LOGO MAY APPEAR ON THE SIDE OR ON BOTTOM OF PART.
- 13 OBSOLETE

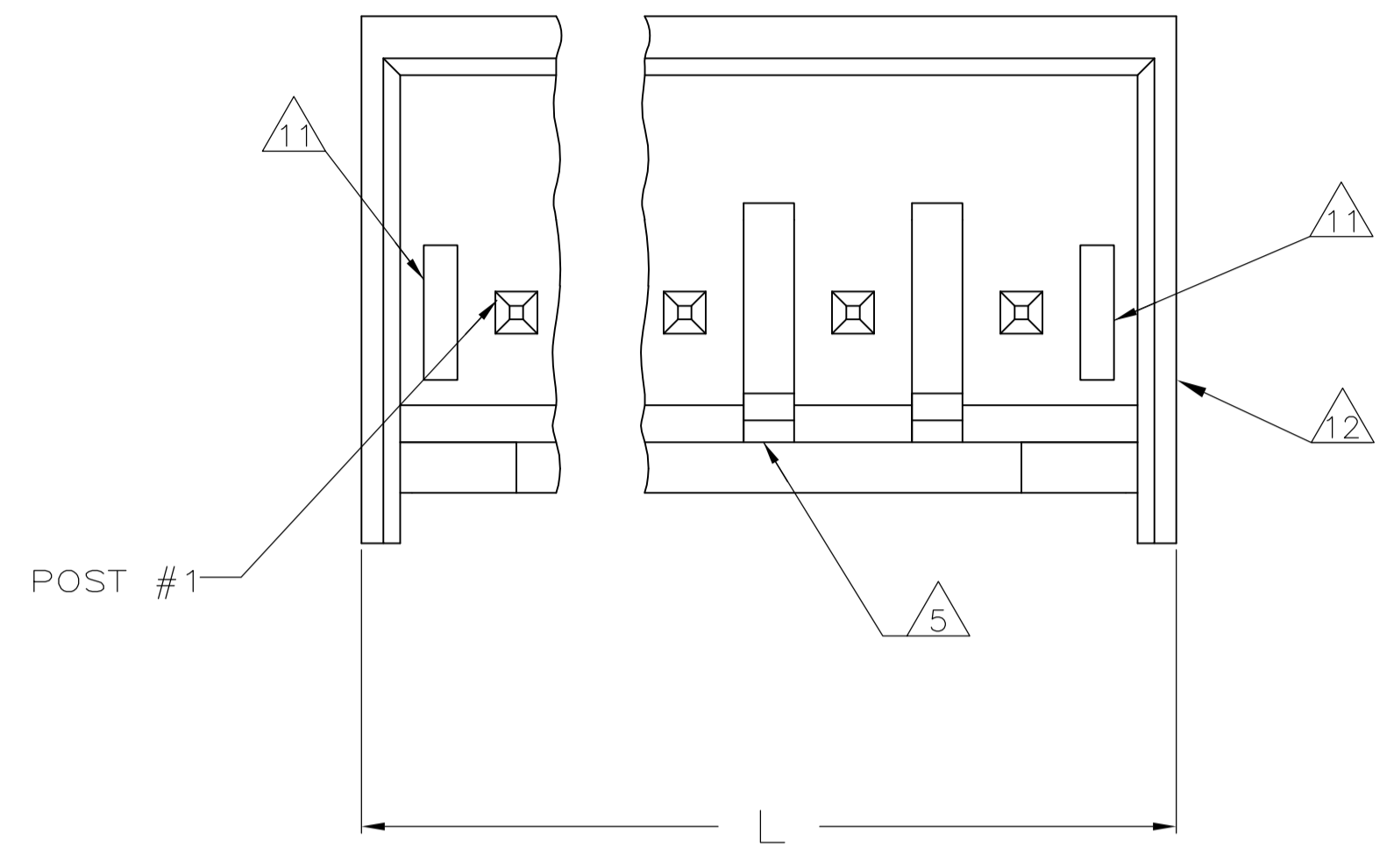
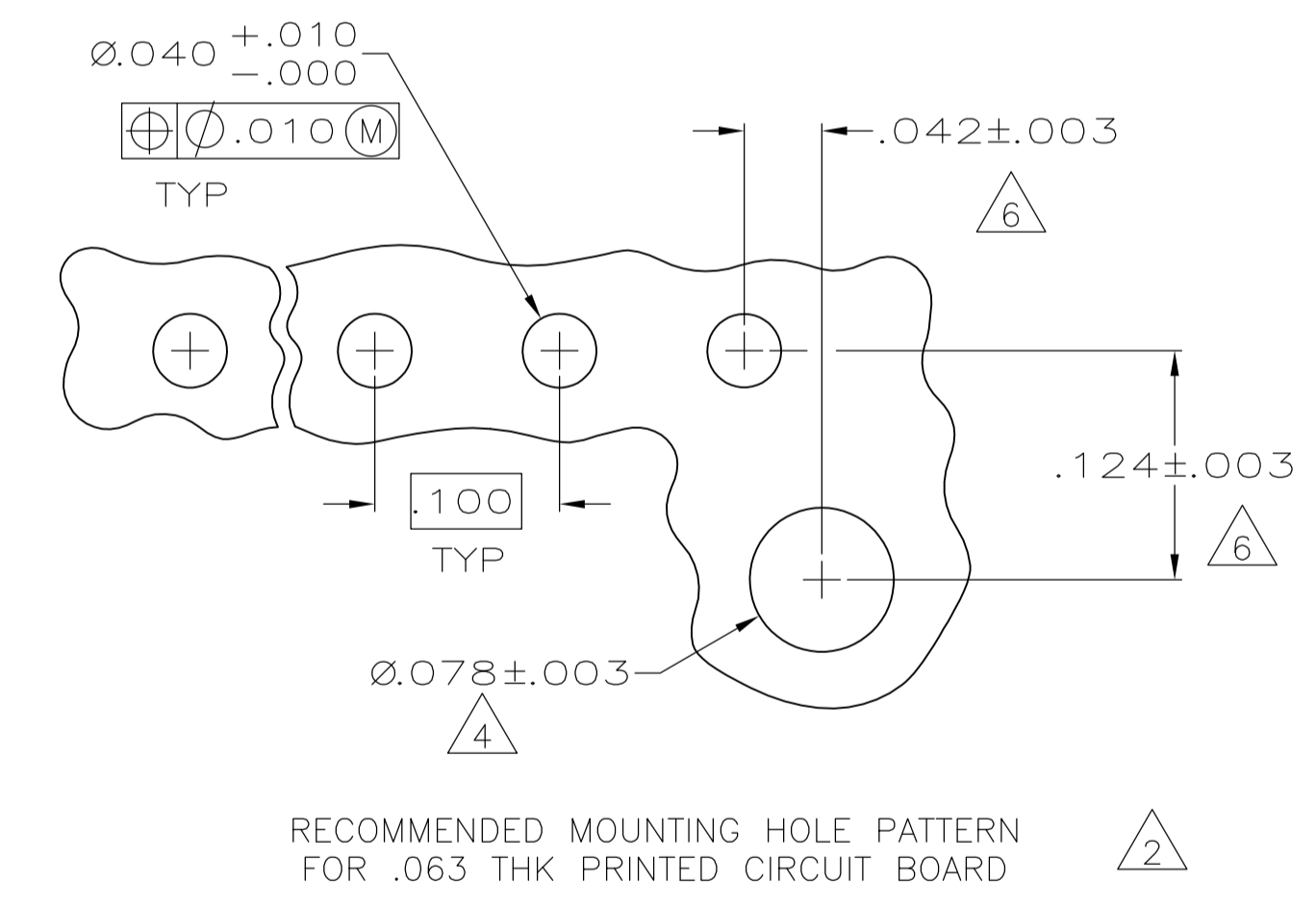
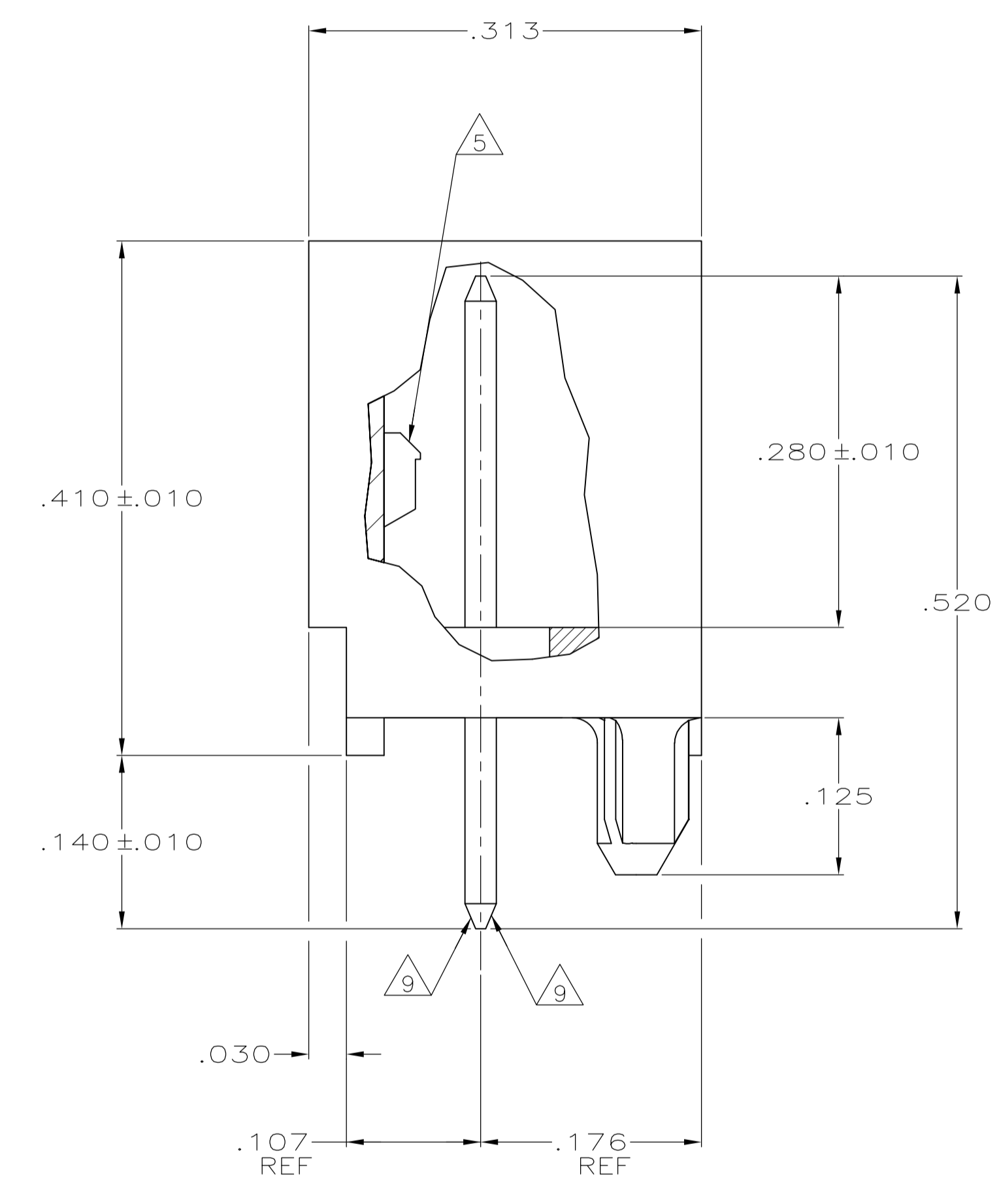
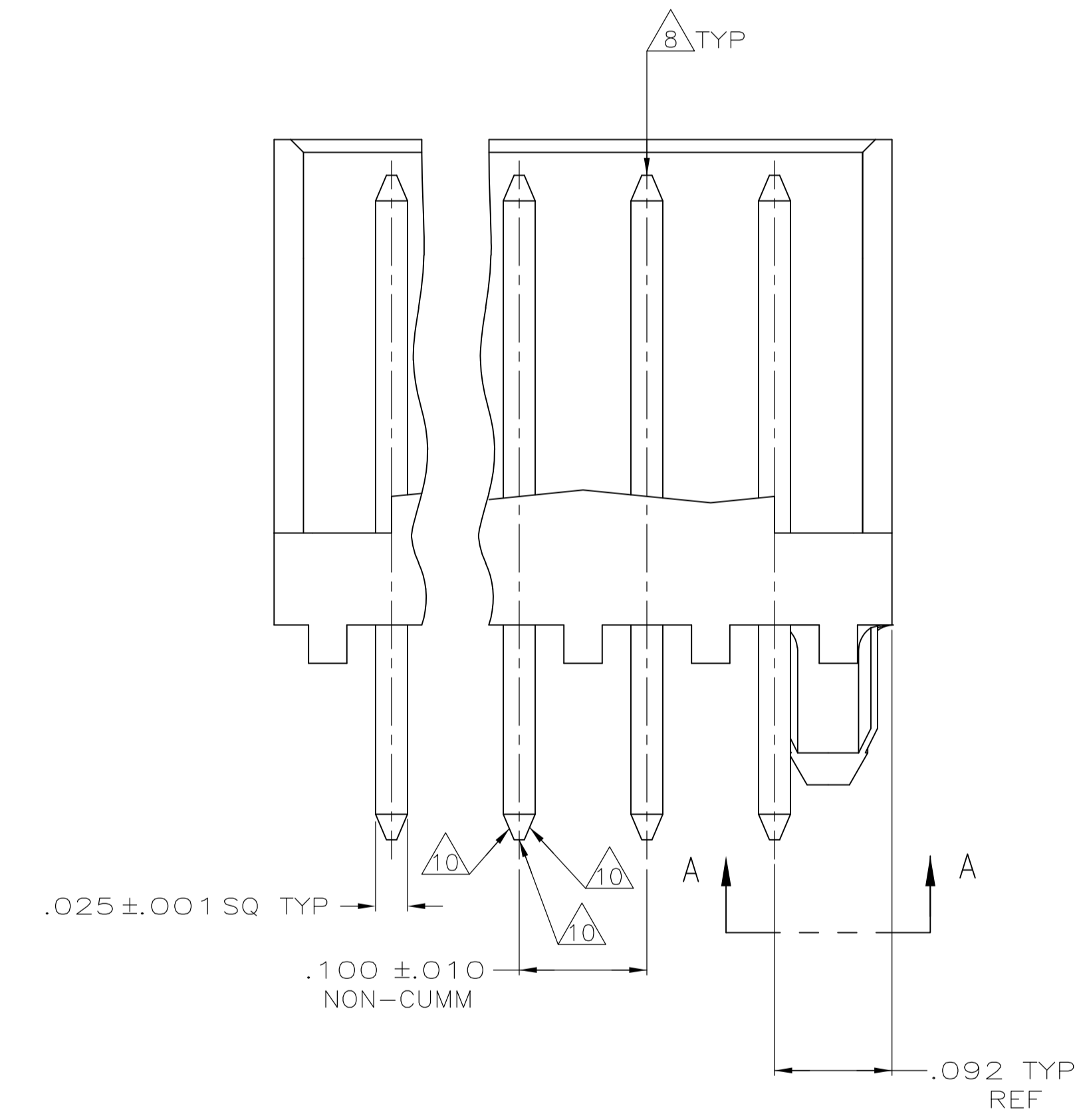

RECOMMENDED MOUNTING HOLE PATTERN FOR .063 THK PRINTED CIRCUIT BOARD

IN	MM	IN	MM	IN	MM
.030	0.76	.124	3.15	-	-
.025	0.64	.107	2.72	-	-
.010	0.25	.100	2.54	.520	13.21
.005	0.13	.092	2.34	.410	10.41
.003	0.08	.078	1.98	.313	7.95
.001	0.03	.063	1.60	.280	7.11
.000350	0.00889	.062	1.57	.176	4.47
.000150	0.00381	.042	1.07	.140	3.56
.000	0.00	.040	1.02	.125	3.18
IN	MM	IN	MM	IN	MM

CONVERSION TABLE

1.484	37.69	14	4-644893-4
1.384	35.15	13	4-644893-3
1.284	32.61	12	4-644893-2
1.184	30.07	11	4-644893-1
1.084	27.53	10	4-644893-0
.984	24.99	9	3-644893-9
.884	22.45	8	3-644893-8
.784	19.91	7	3-644893-7
.684	17.37	6	3-644893-6
.584	14.83	5	3-644893-5
.484	12.29	4	3-644893-4
.384	9.75	3	3-644893-3
.284	7.21	2	3-644893-2
1.484	37.69	14	1-644893-4
1.384	35.15	13	1-644893-3
1.284	32.61	12	1-644893-2
1.184	30.07	11	1-644893-1
1.084	27.53	10	1-644893-0
.984	24.99	9	1-644893-9
.884	22.45	8	1-644893-8
.784	19.91	7	1-644893-7
.684	17.37	6	1-644893-6
.584	14.83	5	1-644893-5
.484	12.29	4	1-644893-4
.384	9.75	3	1-644893-3
.284	7.21	2	1-644893-2

IN	MM	NO OF POSITIONS	PART NUMBER
L			HEADER ASSEMBLY

THIS DRAWING IS A CONTROLLED DOCUMENT.

DIN: K. WHITAKER 24JUNE2005
CHK: D. ROSSI 24JUNE2005
APPV: D. ROSSI 24JUNE2005

NAME: CST-100 SHROUDED HEADER ASSEMBLY, FRICTION LOCK, STRAIGHT POST, TIN OR TIN LEAD PLATED

PRODUCT SPEC: APPLICATION SPEC

SIZE: A1
CAGE CODE: 00779
DRAWING NO: 644893

RESTRICTED TO: CUSTOMER DRAWING

SCALE: 10:1
SHEET: 1 OF 1
REV: G1